

Development Requirements of Ku Band TE₀₁ Mode Dielectric Resonators

Yu Zhang¹, Ying Zhou¹, Kunkun Dong¹

¹CAST—Xi'an Institute of Space Radio Technology, Xi'an, China

Keywords: Ku band, dielectric technology, filter, Wideband dielectric filter.

Abstract: This paper introduces the development status of Ku band Dielectric filters and the wide application of high throughput satellites at the present stage, analyzes the basic principles of the design of Dielectric filters in detail, summarizes the technologies needed in the production and design process, and puts forward the ideas in the process of realizing the relative wideband of Dielectric filters.

1. Introduction

With the development of wireless communication technology, efficient, stable and miniaturized microwave system components have become the focus of people's demands at the present stage. Dielectric filter is an indispensable part of modern microwave relay communication, microwave satellite communication and electronic countermeasures. It has the advantages of low loss, small volume, low frequency temperature coefficient and thermal expansion coefficient. Therefore, it is often used in various scenarios with high performance requirements.

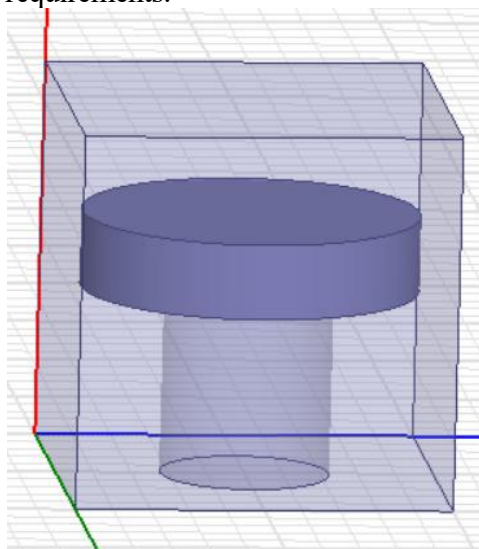

Figure 1: General dielectric resonator.

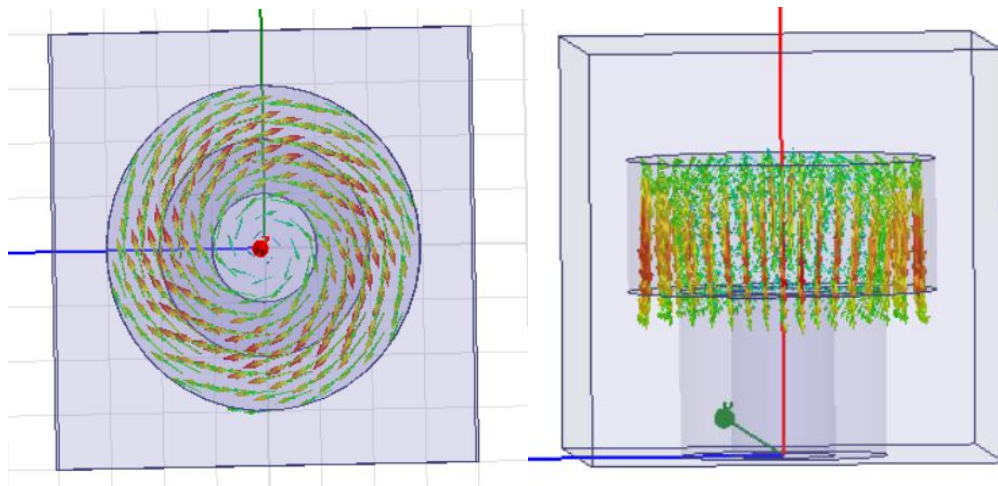

Figure 2: Diagram of electric field and magnetic field distribution of dielectric resonator.

2. Principles of Dielectric Filters

As shown in Figure 1, a dielectric resonator model is shown. The working principle of dielectric resonator is to introduce high-frequency (microwave) electromagnetic waves into dielectric. With the help of electromagnetic wave reflecting continuously at the interface between dielectric and free space, standing wave is formed and oscillation is produced. The filtering principle of the dielectric filter is as follows: the energy of electromagnetic wave is input by the input connector, and the energy is transmitted to the dielectric resonator at the input end, which is transmitted to the adjacent dielectric resonator through resonance, and finally transmitted to the output connector through the dielectric resonator at the output end to realize the output of electromagnetic wave. In this series of resonance process, only the frequency components near the resonance frequency are allowed to pass through, so the band-pass filter is used.

The distribution of the electric and magnetic fields of the TE₀₁ mode dielectric resonator is shown in Figure 2. The TE₀₁ mode dielectric resonator operates in TE₀₁ mode and operates in this mode frequency. It is usually cylindrical or circular. TE₀₁ mode has the following advantages:

1. The electric field and magnetic field are circularly symmetrical;
2. The energy concentration in the dielectric resonator is high, and the Q value of the resonator changes slightly;
3. The mode is easy to identify, and the electrical performance can be measured accurately;
4. The Q value is high.

3. Review of the Status Quo and Development of Dielectric Filters

At present, Japan and the United States are at the forefront of the production level and process technology of dielectric filter, followed by Europe. Murata company of Japan, trans tech company of the United States, Narda microwave West, EPCOS of Germany, Morgan Electroceramics of the United Kingdom and other companies represent the production level and process level of modern microwave ceramic materials and devices.

Scan Qin and Research Institute of Space Electronics Information Technology in China hold a certain number of patents related to Dielectric filters. In the research and development process of 5G, large domestic companies such as Huawei, ZTE and Samsung have also obtained a large number of patents on the research of Dielectric filter. Therefore, the future development of broadband Dielectric filters at home and abroad is bound to be competitive and flourishing.

In the civil field, Dielectric filter is an important component of portable mobile phone, cordless phone, microwave base station, wireless access, TV satellite receiver, etc. Dielectric filter is a key part of 5G. It is a key component in radio frequency. 5G filters need to be more careful and integrated because they need to integrate a large number of electronic components. As a result, ceramic Dielectric filters with small size, reduced loss in transmission, stable frequency and high power characteristics have emerged, which will become the mainstream of future development. Ceramic Dielectric filters have the greatest growth potential in connectors. According to statistical prediction, the size of the filter used in 5G base station will account for 1.556 billion of 15 billion US dollars in connectors by 2020, reaching 10% of the total size, with huge growth potential in the future.

In the direction of aerospace in the military field, there are higher requirements for filters, especially for small size, lightweight devices, high performance and high stability. These urgent requirements make the research of dual-mode dielectric filters designed with the combination of dielectric and dual-mode develop rapidly after the 1980s. As the frequency of military communication satellites increases, the demand for Ku band input multiplexers and Dielectric filters increases.

At present, for high frequency bands, especially for Ku and Ka bands, the input multiplexer mostly uses media technology. In recent years, with the increasing frequency of military communication satellites, the demand for Ku and Ka band input multiplexers is also increasing. In the early 21st century, Ku band input multiplexer mostly uses thin-walled invar cavity dual-mode input multiplexer technology, which takes up a lot of space and mass. In China, the application of dielectric multiplexer on satellite is very difficult because of the restriction of dielectric material and dielectric block bonding technology. However, the invar cavity dual-mode input multiplexer can not meet the requirements of satellite miniaturization and lightweight. At present, the Institute of space electronics and information technology has successfully solved the problem of using dielectric filters to form dielectric multiplexers instead of circular cavity dual-mode input multiplexers.

4. Difficulties in Dielectric Filter Design

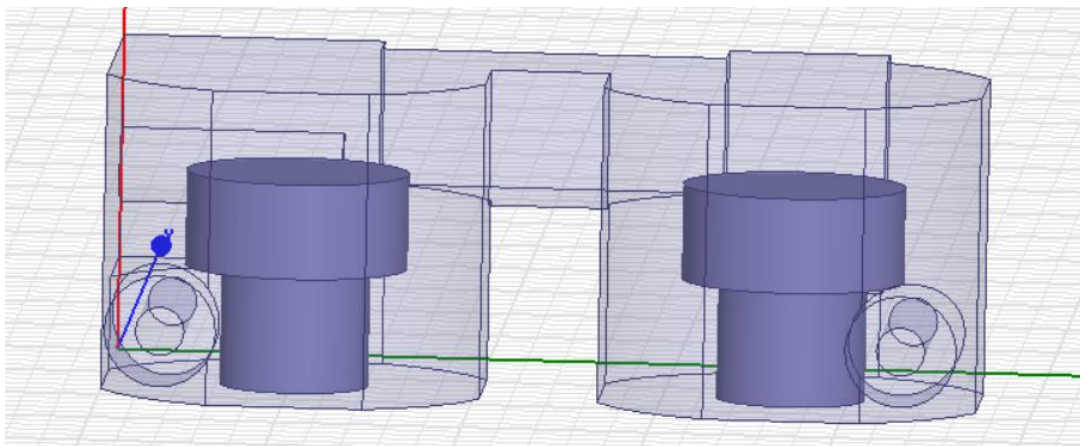

Figure 3: Example of Coupling between Cavity.

The general dielectric resonator model is shown in Figure 3. Traditional dielectric filters often use ceramic materials with high dielectric constants, which are characterized by low insertion loss and high power capacity, but also have some drawbacks, such as narrow bandwidth and large size.

In the process of realizing the design of dielectric filter, the following difficult problems often occur:

(1) The influence of parasitic parameters: When the dielectric resonator works, the mode selected will inhibit the parasitic band and other modes. When the dielectric resonator works in resonance, its resonance frequency will be affected by the resonance frequency from other modes, especially in low-pass filters.

(2) Temperature compensation: Although the temperature coefficient of the dielectric resonator is very stable, one or two additional metal chambers are needed to make the dielectric resonator. This is because the temperature drift of the dielectric is large and only the metal chamber can be used to offset the temperature drift constant of the dielectric.

(3) Fast dielectric adhesion: whether the dielectric and the metal are assembled together to make them tightly bonded, because the precise combination of the two materials will directly change the distribution of the electromagnetic field, resulting in the resonance failure of the resonator;

(4) Fast debugging: In order to satisfy the high performance index, high order, multiple cross-coupling in satellite communication, it is very difficult to debug high frequency Dielectric filters. Therefore, the fast debugging technology of filters must be solved in the research process.

5. Solutions

In recent years, with the rapid development of ultra-wideband system, broadband bandpass filter has been widely used in this area. A good performance broadband filter requires several features: low insertion loss, sharp transition band, small size, and so on. With the development of filtering technology, various kinds of broadband filters have been structured in a variety of ways, resulting in various coupling structures.

For the dielectric filter, the size of the dielectric block, the size of the coupling hole in the cavity, and the length of the cross-coupling rod are mainly determined. There is a frequency modulation screw on each cavity and a frequency modulation coupling screw between the two cavities.

For these reasons, future filter design needs to be improved on the basis of original Dielectric filter design to achieve the characteristics of Ku band broadband and reduce the filter volume to a certain extent.

The amount of coupling to achieve broadband is critical. There are three ways to achieve this:

(1) By optimizing the topological structure of the coupling matrix, the coupling matrix coefficients can be as small as possible, which reduces the difficulty of achieving the coupling amount; or by changing the polarity of the coupling matrix at different locations, the design of the product can be simplified.

(2) Abnormal media can be used to increase the coupling without changing the position of the cavity.

(3) Increase the coupling amount by shortening the distance between the chambers, but at the same time, additional parasitic coupling and wide-band dispersion effects will be introduced.

In the future, this method will be further studied, and simulation analysis will be carried out by iteratively updating the coupling matrix and parameter collaboration.

References

- [1] Floor brilliance. *Design and preparation of dielectric loading chamber and monolithic duplexer [D]. [Published in unknown]: Central China University of Science and Technology, 2016.*
- [2] C. Kudsia, R. J. Cameron, W. C. Tang. *Innovations In microwave filters and multiplexing networks for communications satellite systems[J].IEEE Trans On Microwave Theory Tech, 1992, Vol.40 (no.6): 1133-1149.*
- [3] J. Uher, J. Bornemann, U. Rosenberg. *Waveguide Components for Antenna Feed Systems: Theory and CAD[M]. Norwood: Artech House, 1993.*
- [4] Liu Ye, Ma Chunqing, Tuolin, Yu Yanhong. *Technical analysis of site selection for KU-band satellite earth station [J]. China New Communications, 2019,21(09): 80.*
- [5] Zhang Rundong. *Severe snowfall cuts off TV signal [N]. Beijing Times, 2003-11-07.*
- [6] Xiao Zhi. *Passive device design based on LTCC technology [D]. [Published in unknown]: Xi'an University of Electronic Science and Technology, 2006.*